



WJA TYPE BARREL COUPLING

Installation and maintenance instruction

DENSEN GROUP

This instruction manual is for general guidance only. It describes, in general terms, how to install and handle our product. It does not describe in detail your purchased product. The instruction manual may not be used as basis for customer complaints or warranty claims.

1. Scope of application

It is suitable for the connection between the reducer and the rotated parts of cranes, transporters, coal selectors and construction machinery, etc. It can withstand large radial loads and transmit large torque. The coupling is flexible and easy to install for lifting mechanism.

2. Safety instructions

The coupling may only be used and operated within the scope of the conditions specified in the service and supply agreement. These assembly and operating instructions are part of the coupling delivery. Keep them accessible near the coupling.

- Read through these instructions carefully before carrying out any assembly or maintenance work.
- Couplings may only be assembled or installed by competent personnel and only for suitable application cases.
- No liability claims can be made in the event of noncompliance with the information in these instructions.
- Visibly damaged couplings or their components may not be assembled or put into operation.
- If changes in the coupling are detected during operation the drive should be switched off immediately;
- Only use original spare parts.

The relevant occupational safety and environmental protection regulations must be observed during transport, assembly, dismantling and maintenance. Make sure that suitable means of transport are available and are used.



Rotating machine parts can injure operators and service personnel!

Therefore:

1. Switch off the drive before starting assembly work.
2. Secure the machine against accidental switching on (lock-out).
3. Fit all covers, protective devices and guards before switching on the machine.

3. Transportation and storage

- The barrel coupling is assembled and delivered as a whole, and must be filled with sufficient suitable lubricants before being put into use;
- Avoid collisions during transportation and storage;
- If the coupling needs to be stored for a long time, it is necessary to provide long-term protection, and the storage space should be dry, dustproof, and the humidity of the air should preferably be below 50%.

4. Structural diagram

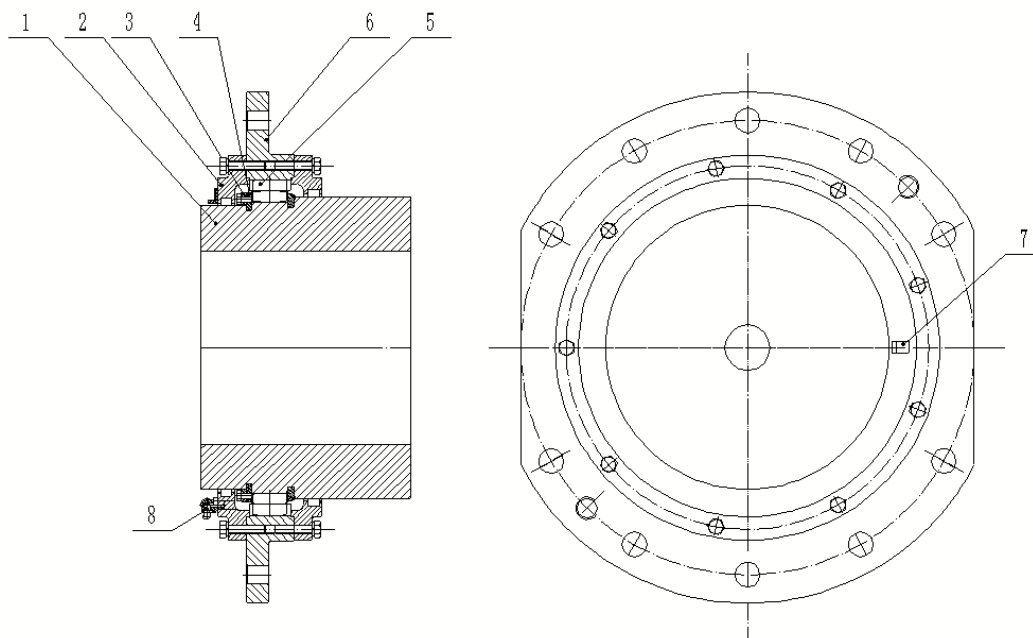

Figure 1

- (1) Inner ring (2)cover plate (3)connecting piece (4)retaining ring
(5)pin roller (6)outer ring (7)indicator piece (8)oil cup

The pin roller is installed in the cylindrical groove of the (1) inner ring and the (6) outer ring, transmitting torque and radial force through the pin roller, while compensating for certain angular deviation.

The included angle should not be too large in use, and the better the installation accuracy, the better the use effect, and can greatly extend the service life.

5. The mounting form is shown below:

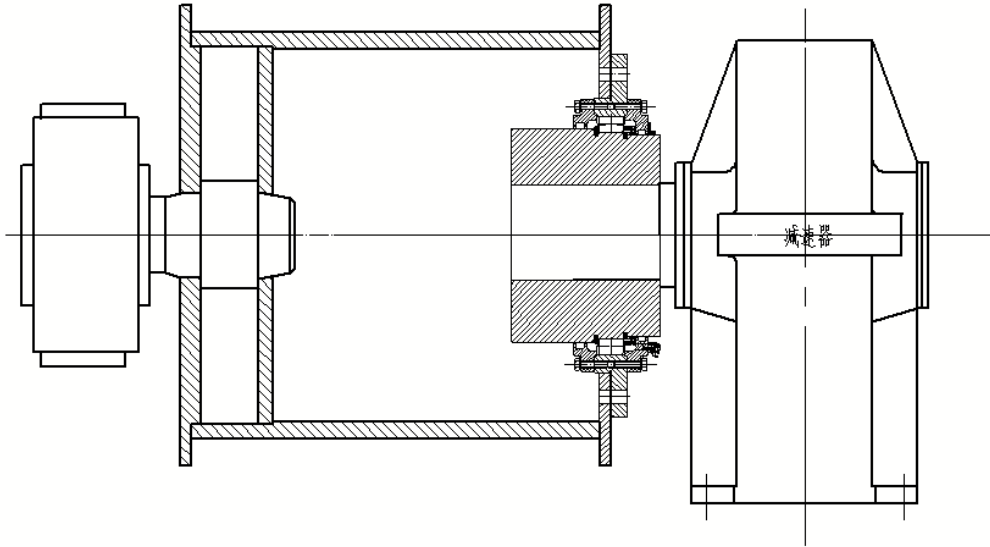

Figure 2



Ensure that there is no axial movement between the coupling and the shaft. When using a complete set of couplings for hot installation, the entire coupling is heated using gas as the heating medium (such as being placed in an electric heating box for heating), with a heating temperature not exceeding 130 °C. After cooling, please fill it with oil in a timely manner.

6. Installation

- Confirm that the inner hole of the coupling has been machined according to the size of the shaft to be connected;
- Installation needs to be completed by trained personnel;
- Pay attention to ensuring sufficient space for installation and subsequent maintenance and repair work;
- Remove rust, dirt, grease, and pigments from the inner hole of the coupling inner ring and the connected shaft;
- The flange joint surface connected to the drum coupling should not have oil stains during assembly;
- One end of the drum is supported on the output shaft of the reducer through a coupling, and the other end is supported by a bearing sea

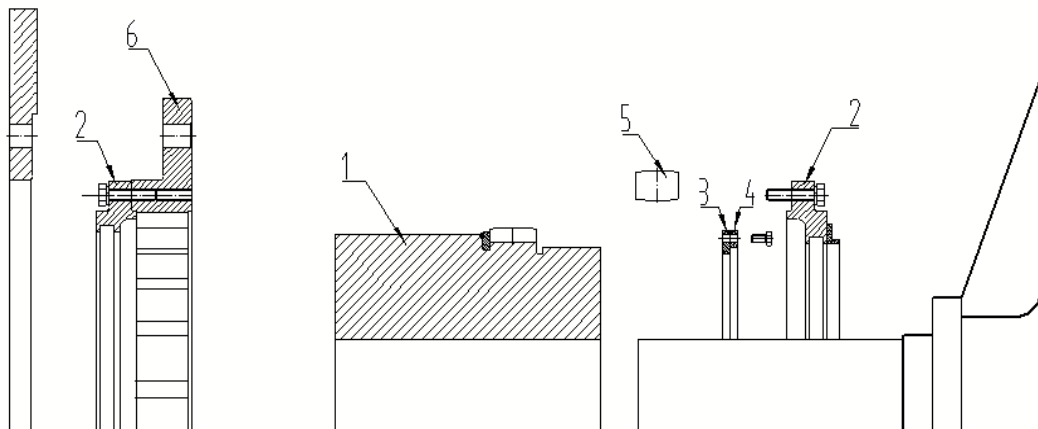

Figure 3



Before installing the (1) inner ring heating onto the reducer shaft, first place the (2) cover plate, (3) connecting plate, (4) retaining ring, and internal sealing ring on the reducer shaft to ensure that they do not come into contact when heating the (1) inner ring.

Install the bolts in the appropriate position as shown in the assembly drawing. The cover plate connecting bolts adopt a bolt pre tightening force of 8.8 grade, as shown in the table below

Thread specification mm	M8	M10	M12	M16	M20	M24
Prestressing NM	15	30	50	120	240	400

Table 1

7. Calibration

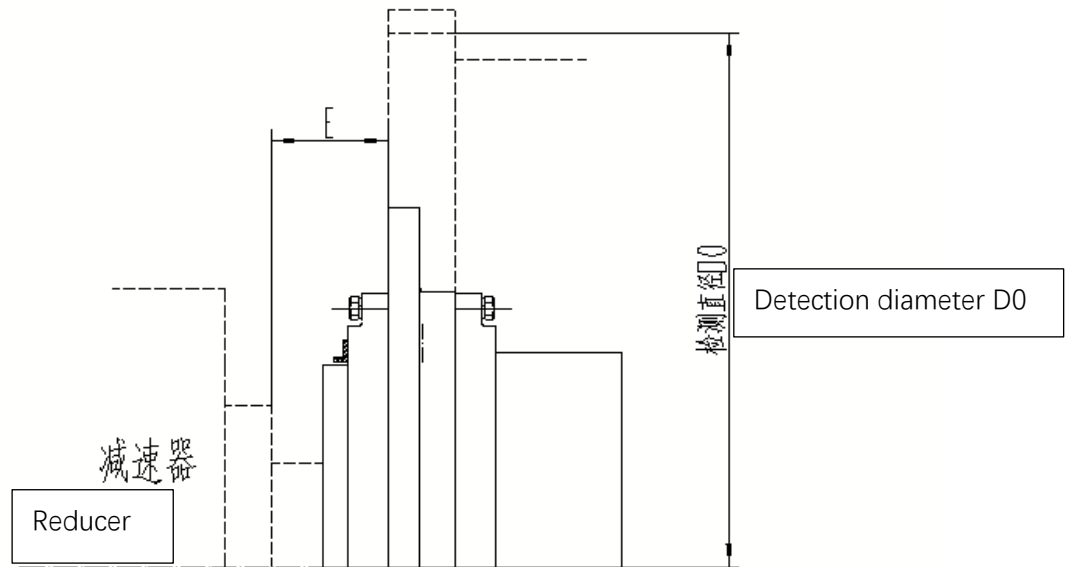

Figure 4

According to the detection diameter D_0 and an interval of 90° , measure the distance E between the reducer end face and the roll end face (see Figure 4), and the difference between any two values measured should not exceed the provisions of Table 2

	mm	
Detecting Diameter D_0	≤ 1000	> 1000
The difference in measured E is less than $<$	0.8	1.2

Table 2

8. Maintenance

- Couplings are generally lubricated with No. 2 extreme pressure lithium grease, and No. 3 lithium grease is suitable for lubrication under high temperature conditions.
- The relative position between the wear indicator of the coupling and the wear indicator screw (or groove), as well as the connection screw and lubrication condition, should be checked at least every three months. If the pointer contacts the wear indicator screw (or groove), the coupling needs to be replaced.
- Add lubricating grease to the coupling at least once a year.



Note: WJA type barrel couplings do not withstand or transmit axial forces in the transmission system. The maximum comprehensive axial force generated by the tension of the steel wire rope and the inertia force of the drum in the lifting mechanism of the crane must be borne by the bearing seat at the tail of the drum.